

**TOOLS : Basic Electronics & Arduino Micro controller**

# Current

Current (I) is measured in units called amperes (A). The ampere is the rate of flow of electrons during a fixed period of time. One ampere is 6,250,000,000,000,000,000 or  $6.25 \times 10^{18}$  electrons *during one second of time*.

Current (I) is the number of electrons flowing past a point during a fixed period of time.

While current refers to the passage of electrons there are also a number of different kinds of current. Direct current (DC) is current that always flows in the same direction. That is, the electrons move in one direction from atom to atom.

DC is the current that runs most of our microcontrollers and other consumer electronic items, but this type of power must come either from a DC source such as a battery or from somewhere else like a converted AC power source.

Alternating current (AC) is current that varies in magnitude and changes direction periodically. AC is the way power stations and generating stations distribute large quantities of power around the country. It is used because periodically changing the direction and magnitude of the current flow reduces the heat and friction of the electrons.

The current that comes out of your wall socket is AC and runs at 60 Hertz (Hz). Hz designates the frequency of an AC source. The reversing of the direction of AC flow keeps the wires from getting too hot, especially for high power wires conducting tens of thousands of AC volts.

The word Hertz comes from the German physicist Heinrich Rudolph Hertz (1857--94), who was the first to artificially produce electromagnetic waves. Hertz is also a unit of frequency, where one Hertz is equal to a periodic interval of one cycle per second.

# Voltage

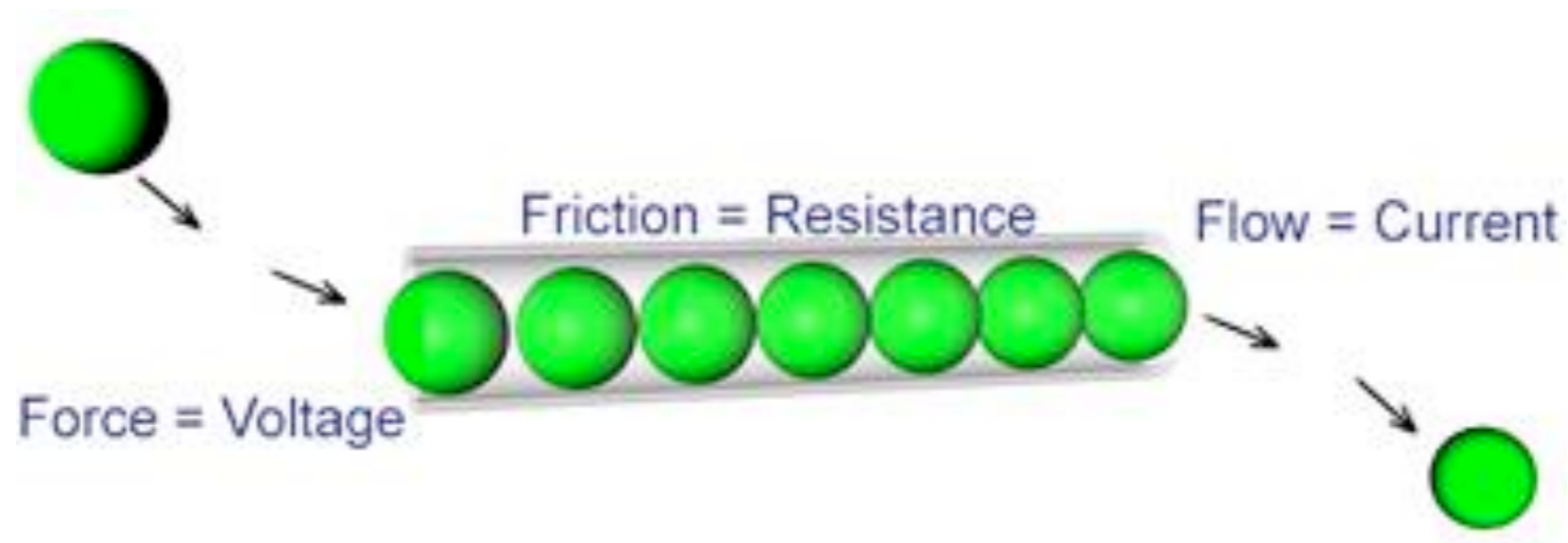

- Well, we can call this pile of electrons **voltage**, designated as **V** or **E**, which is measured in volts. The AC current that comes out of the wall socket is 115 volts.

- **Voltage (V or E)** is electrical potential, or the potential difference between two points, and is measured in volts.

- Voltage is electrical pressure or force. It can also be thought of as a potential difference between two points in charged space. The electrical pressure pushing the current is voltage.

- **Transformers** are used for converting one voltage to another using induction. What you use to charge your phones, computers, etc. “the black box” also called a “wall wart” is a transformer. That small box is changing the 115 volts of AC energy to the appropriate amount of DC voltage to charge your device.

- **Polarity:** is a word that allows us to refer to the + or – side of a DC source of voltage. You will be measuring polarity later in this chapter. Many electronic components have polarity and it is important to check and note the polarity of transformers, components like LEDs, Capacitors, Transistors, which we will learn about soon.

ARDUINO: The arduino functions using DC voltage. Nearly all of your projects and assignments will only use small amounts of DC voltage.



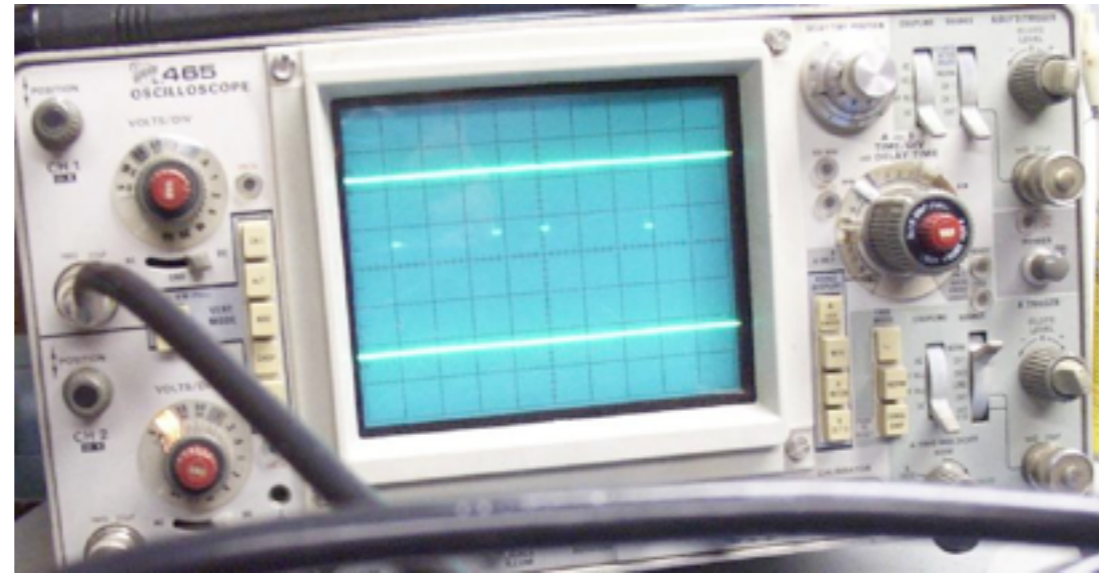
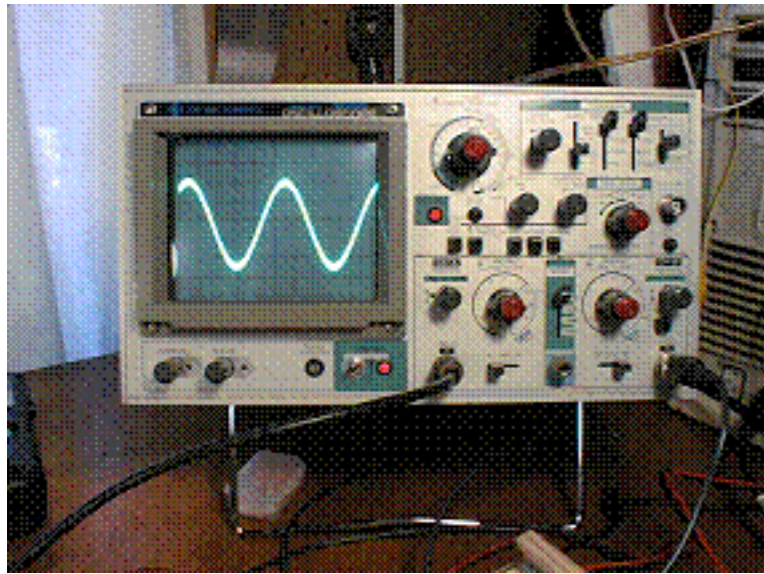

**Frequency is the number of cycles over a certain period of time and is generally measured in Hz.**

**DC can have a frequency of varying magnitude, but it will not change direction like AC. Many of you are familiar with the phrase Gigahertz (GHz) from the frequency of your computer processor. A GHz is one billion Hz, or one billion cycles per second. You can have a frequency of 20 Hz or 50 Hz, for instance. Computers use a cycling DC waveform in the GHz range to perform arithmetic computations. The waveform used in computers is a square wave, meaning it will change from 0v to 5v in one cycle. Note that this is different from an AC frequency because only the magnitude of voltages changes, and will never switch from a negative to a positive or vice versa. A typical cycle for AC will progress from a positive voltage, through zero volts, and down to a negative voltage in one cycle.**

**In the early part of our century, when the captains of industry, Thomas Edison, invented the light bulb, he knew he needed a system to distribute the power necessary to light his bulbs. Edison established local DC generating systems to create the DC distribution network necessary to power his bulbs and motors. Simultaneously, the Westinghouse Electric Company with the inventions of brilliant Nicola Tesla, who was developing AC motors, introduced the competing system of AC. The war of the currents began between Edison's system of DC and Westinghouse's AC distribution system. Many dogs, and cats were electrocuted in this war in each side's attempts to prove that their mode of electrical power distribution was superior. (just a fun factoid)**

# Resistance

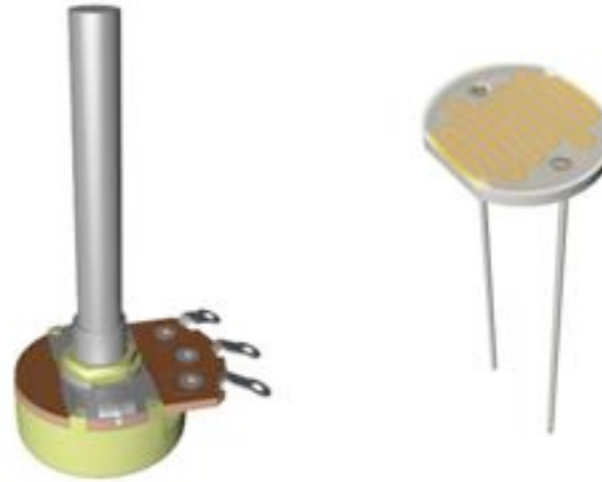
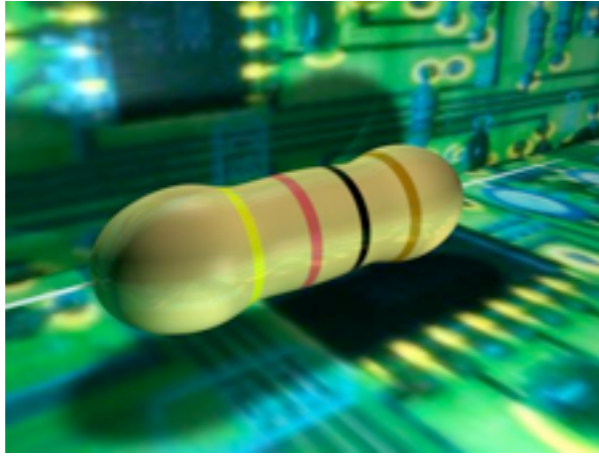

Resistors are devices that are composed of materials that cause an electrical resistance. They are used for current control because they limit the passage of electrons and cut down on voltage pressure.

- Because many electronic devices are sensitive to too much current and voltage, resistors will be the primary devices you use in limiting the current and voltage flow entering your sensitive electronic parts.

Resistors function by limiting or resisting the passage of electrons, and in this process, they cut down on current pressure, which protects the parts.

Resistors can have a single fixed value or they can be variable. Variable resistors allow you to change the resistance by turning a dial or moving a knob (directly below). Variable resistors are very common, and each time you turn the knob of your stereo you are varying the number of electrons pushing on your speaker to pump up the volume or TURN DOWN THAT NOISE!

A photo resistor resistance changes in relation to the amount of light it is exposed to. Photo resistors can be used in creating circuits that are triggered by passing shadows.

Variable resistor. Here you would hook the middle leg and one of the outside legs into a complete circuit to get the variable resistance. 3D model by Jessica Miler.

A photo resistor changes resistance in relation to the varying light levels it receives. Note: Photo resistors are semiconductors and therefore not passive. More in chapter 5 3D model Michael Tanzillo.

Resistors receive electrons from a voltage source based on voltage pressure and they function by not allowing all of the electrons that enter into the resistor to pass out of the resistor in a given period of time.

As electrons are pushed through a resistor by a force of voltage like a battery, some of the electrons randomly collide with the atoms within the resistor, which creates heat. These mini collisions within the atoms cause vibrations, and these vibrations are passed to air molecules in the form of heat. This is one reason why electronic components are often hot, and why electronic cases have holes that allow the excess heat to escape.

This will also give you the first design clue for creating your own project and invention. Make sure the electronics in your project have access to circulating air so the heat created in the process of electrical resistance can pass out of the container.

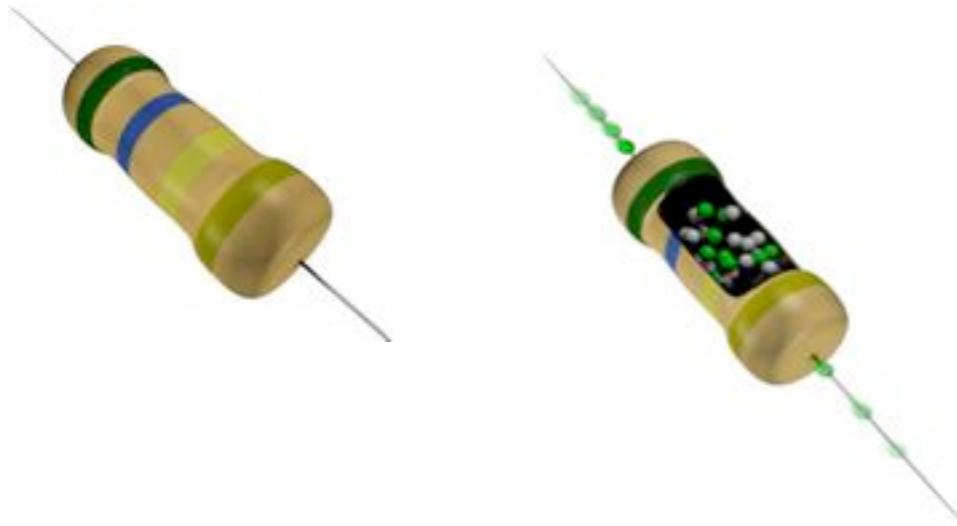

-Many resistors are composed of carbon and a glue-like binder, though there are many other types of resistors made from different materials such as coiled wire and film. Other classes of resistors are selected based on the characteristics of their ability to absorb heat and remain stable, to resist moisture, or to resist solvents. Some resistors are designed for special high power applications

-Visualization of electron flow in a resistor that is attached to a voltage source--many electrons enter and fewer come out.

-In a carbon resistor, you can increase or decrease the resistance by choosing a resistor that increases or decreases the amount of carbon in relation to the glue-like binder. Carbon is the conductive molecule in this material mix.

- Even the graphite lead in your 2B pencil is a carbon resistor, and some artists have exploited the resistive qualities of lead pencils in the creation of art.

- You must be aware of the Wattage rating of resistors as it refers to the amount of current resistors can absorb and be given off as heat. As with wire generally the thicker a resistor the more electrons you can push through it and the more heat it can withstand.

- The most common wattage sizes are 1/8, 1/4, and 1/2 watt. You will be using 1/4-watt resistors for the lessons in this book. There are also 1, 2, and 10 watt resistors and resistors with 10,000 watts for large industrial applications.

- If you try to push too much pressure of voltage and amperage through a resistor that is not able to absorb all the molecular collisions they can overheat and may burn up. This can be a smelly and smoky affair. Resistors are designed to absorb given amounts of electron current (I) measured in amps (A) and dissipate power (P) measured in watts (w) that is transferred as heat or light.



In the image above, notice the different thicknesses of the resistors. The large 100 and 10 watt resistors have more mass to absorb and pass more electrons, and more surface area, which comes into contact with cooling air that allows the heat to be wicked off the surface of the resistor. The red 50 watt resistor has a hole through the middle of the resistor. The hole increases the surface area to allow heat to be wicked off by cooling air.

In the smaller carbon resistors at the top of this image above, notice how the resistors increase in wattage rating from 1/4 to 2 watts as they increase in size. In order to properly select resistors you will need to understand how to measure them with a multimeter as well as understand how the color codes that circle the resistor related to the quantity of resistance. You can calculate the quantity of resistance available in a resistor by looking at the color bands around the resistor. Each color band has an associated number assigned to it. Here are a variety of [resistor chart](#).

You can identify resistance available in a resistor by the color band chart. You can also measure resistance with your multimeter

The quantity of resistance is measured in ohms, named after Georg Simon Ohm (1787--1854). This is designated by the omega ( $\Omega$ ) symbol.

It simply refers to the quantity of resistance or ohms that a material presents to the passage of electrons. So if a resistors color bands give you a value of 1000. then we would say that resistor is a 1000 ohm resistor or 1000  $\Omega$  resistor or 1K $\Omega$  resistor. These are all equivalent.

## READING RESISTANCE VALUES

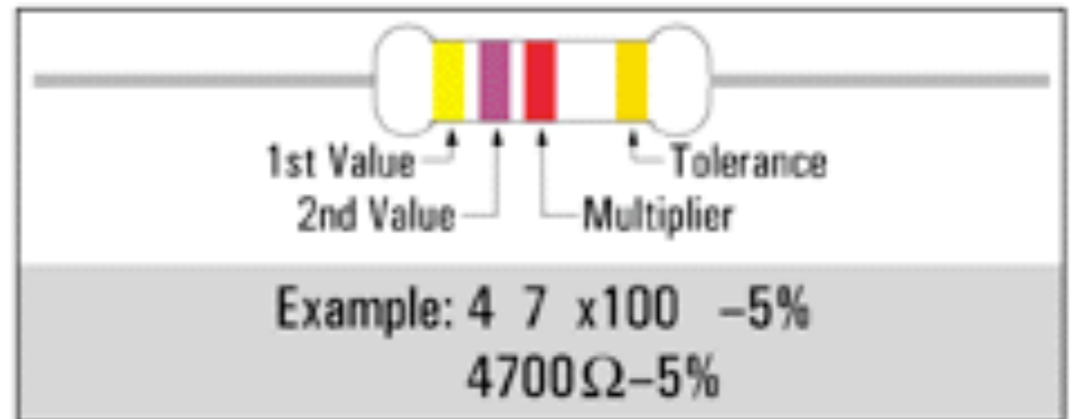

COLOR	VALUE	MULTIPLIER	TOLERANCE
Black	0	1	-
Brown	1	10	-1%
Red	2	100	-2%
Orange	3	1K	-
Yellow	4	10K	-
Green	5	100K	-.5%
Blue	6	1M	-.25%
Violet	7	10M	-.1%
Gray	8	100M	-.05%
White	9	1000M	-
Gold	-	1/10	-5%
Silver	-	1/100	-10%
None	-	-	-20%

# Ohm's Law

Georg Ohm (1789-- 1854) defined an important relationship between voltage, current, and resistance, now called Ohm's law which states: **a potential difference of one volt will force a current of one ampere through a resistance of one ohm.**

Mathematically, Ohm's law can be written as:  $I = E/R$ , where **I** is current, **E** is applied voltage, and **R** is the resistance in ohms. It can also be written as  $E = I \cdot R$  or  $R = E/I$ .



To understand Ohm's law and the relationship between voltage, resistance, and current flow, the water analogy is one way to think about this relationship. (directly below).



# Ohm's Law Continued

The liquid flow decreases when the faucet is closed. This is analogous to high value resistance constricting the width of the electron pipe, so fewer electrons pass in a given period. Therefore, high resistance decreases the flow of electrons, but the water analogy also allows identification of the idea of electron pressure or electron quantity as it relates to the possible flow.

With Ohm's law, you can now calculate what size resistor you will need to protect a sensitive electronic part that is not able to withstand large quantities of electrons in a given period of time. Remember how we defined a fuse as a thin wire that would burn up and melt if too many electrons are being pushed through in a given period of time? Well, resistors can prevent sensitive parts from burning up by absorbing and giving off as heat some of that electron energy.

With Ohms law if you are given any two values in a circuit, you can always solve for the third value using simple algebra. Often when you purchase parts the data sheet on the back of the package will say that the electronic device will work with a certain voltage like 5-volts DC. The package will also say that the electronic part only can withstand a certain amount of amperage or milliamperage.

With Ohm's law, you can now calculate that a resistor of a particular size will allow a 5-volt source to deliver a certain amount of amperage in one second of time. Fortunately, Ohm's law works for AC, DC, and radio frequencies (RF).

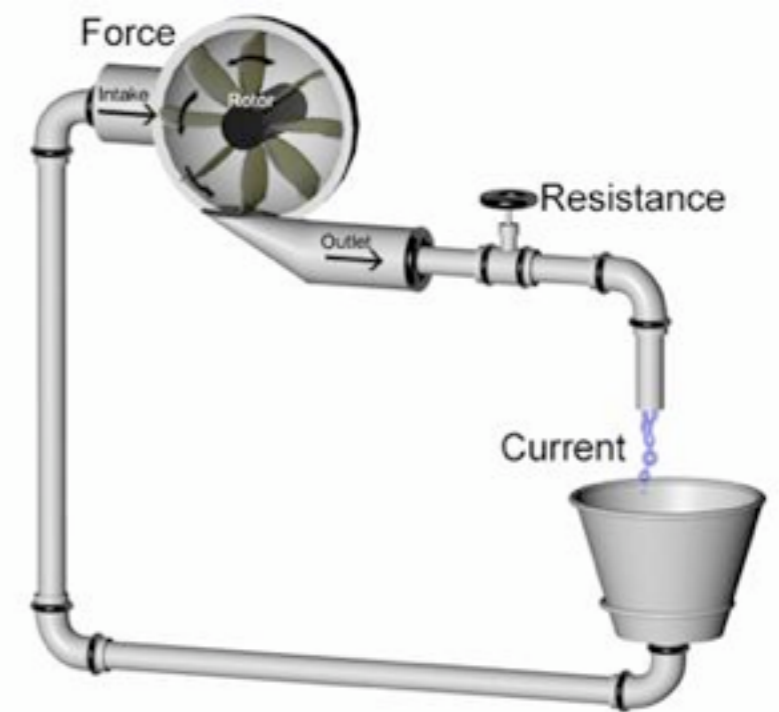

# Using a Multimeter

- DC Current From Transformer
- AC Current From Transformer
- DC Current from Battery
- Resistance
- Continuity

Most meters have removable wires, known as *leads* (pronounced “leeds”). Most meters also have three sockets on the front, the leftmost one usually being reserved to measure high electrical currents (flows of electricity). We can ignore that one for now.

The leads will probably be black and red. The black wire plugs into a socket labeled “COM” or “Common.” Plug the red one into the socket labeled “V” or “volts.”

The other ends of the leads terminate in metal spikes known as *probes*, which you will be touching to components when you want to make electrical measurements. The probes detect electricity; they don’t emit it in significant quantities. Therefore, they cannot hurt you unless you poke yourself with their sharp ends.

If your meter doesn’t do auto-ranging, each position on the dial will have a number beside it. This number means “no higher than.” For instance if you want to check a 6-volt battery, and one position on the voltage section of the dial is numbered 2 and the next position is numbered 20, position 2 means “no higher than 2 volts.” You have to go to the next position, which means “no higher than 20 volts.”



# DECONSTRUCTION & COMPONENTS



# Circuit Sidekick

# Review of Components

# Schematics & Symbols

Symbol



Resistor

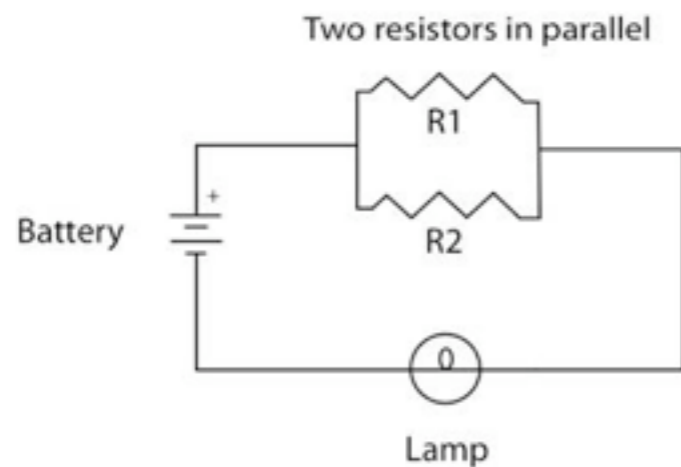
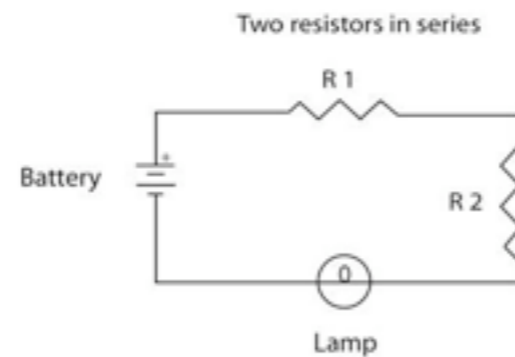
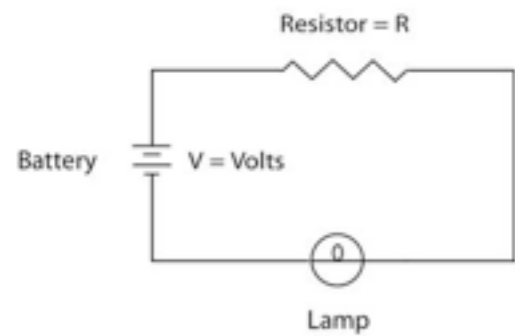

-When working with electronics, it is important that we have a language to communicate electronic designs. The excitement of being able to read the maps will become apparent as you learn electronics since maps of possible circuits are freely available. A schematic is a map that tells us how to build circuits. They are constructed of symbols, which refer to different electronic parts.

Artists and engineers are visual thinkers and can see things three dimensionally however engineers have also constructed a marvelous symbolic language to describe circuits and their connections, and this language also makes a lot of sense to artists.

For example, (image below) shows the symbol for the resistor and a 3D model of a resistor to the right. The crooked line communicates that as the electrons enter the resistor they are reduced in quantity or slowed down, as in a crooked road that may slow your car down. You can also think of the resistor symbols, crooked line, as a wave of heat which is the resistor getting hot with all the quantum vibrations of electrons striking the nuclei of the carbon atoms within the resistor.



# Review of Electricity

Copper Wire

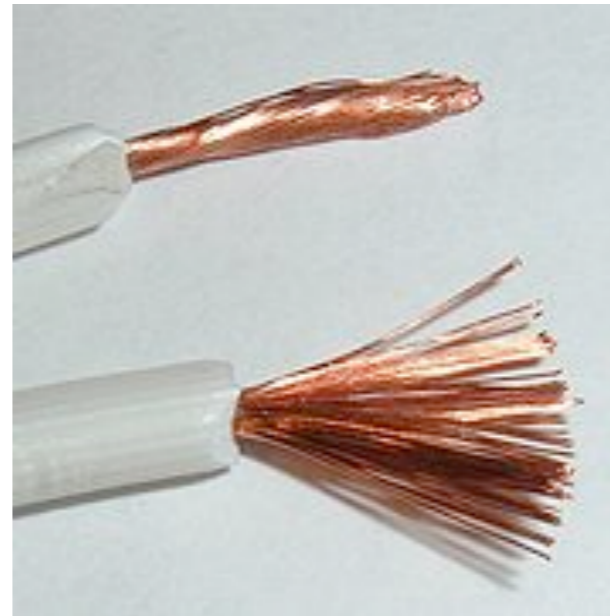
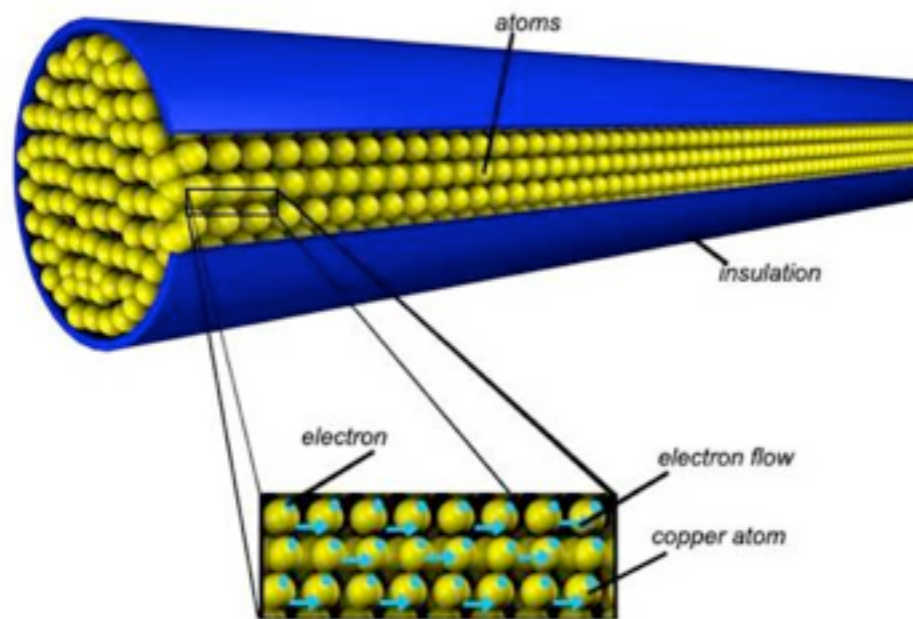

- All matter is made up of atoms, and atoms are made up of smaller particles. The three main particles making up an atom are the proton, the neutron, and the electron.
- Electrons spin around the center (nucleus) of atoms in the same way that the moon spins around the earth. The nucleus is made up of neutrons and protons
- Electrons contain a negative charge, protons a positive charge. Neutrons are neutral- they have no charge
- When electrons move along the atoms of matter, a current of electricity is created. This is what happens in a piece of wire.- The electrons are passed from atom to atom, creating an electrical current from one end to the other.
- The flow of electrons (electricity) through the material (for example, wire) is proportional to the mass of the conductive material, and the density of electrons available.
- Resistance in wire depends on how thick and long it is, and what it is made of. The thickness of wire is called its gauge. The smaller the gauge, the bigger the wire. There are also different types of wire that vary the type of current you will use for your projects. Typically we will be using copper stranded and solid wire for our projects.

# SOLDERING

Soldering is defined as "the joining of metals by a fusion of alloys which have relatively low melting points". In other words, you use a metal that has a low melting point to adhere the surfaces to be soldered together. Consider that soldering is more like gluing with molten metal, unlike welding where the base metals are actually melted and combined. Soldering is also a must have skill for all sorts of electrical and electronics work. It is also a skill that must be taught correctly and developed with practice.

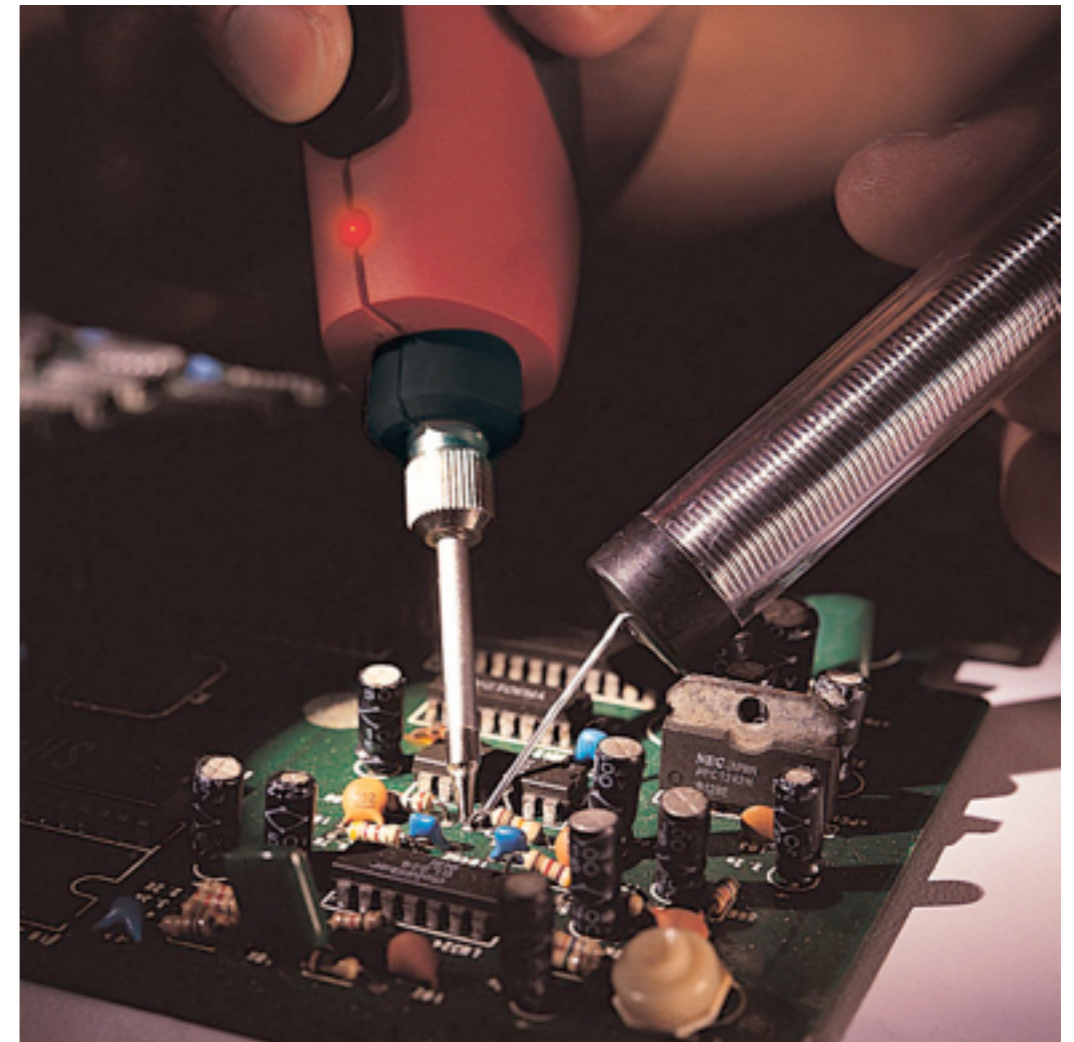

# SOLDERING TOOLS & MATERIALS



## The Soldering Iron/Gun

The first thing you will need is a soldering iron, which is the heat source used to melt solder. Irons of the 15W to 30W range are good for most electronics/printed circuit board work. Anything higher in wattage and you risk damaging either the component or the board. If you intend to solder heavy components and thick wire, then you will want to invest in an iron of higher wattage (40W and above) or one of the large soldering guns. The main difference between an iron and a gun is that an iron is pencil shaped and designed with a pinpoint heat source for precise work, while a gun is in a familiar gun shape with a large high wattage tip heated by flowing electrical current directly through it.

DO NOT SET THE IRON DIRECTLY ON THE TABLE- USE YOUR LITTLE METAL STAND FROM YOUR KIT TO REST THE GUN ON. IT WILL GET HOT

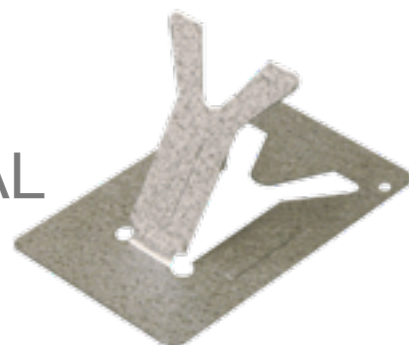



# SOLDERING TOOLS & MATERIALS

## Solder

The choice of solder is also important. There are several kinds of solder available but only a few are suitable for electronics work. Most importantly, you will only use *rosin core solder*. *Acid core solder* is common in hardware stores and home improvement stores, but meant for soldering copper plumbing pipes and not electronic circuits. If acid core solder is used on electronics, the acid will destroy the traces on the printed circuit board and erode the component leads. It can also form a conductive layer leading to shorts.

For most printed circuit board work, a solder with a diameter of 0.75MM to 1.0MM is desirable. Thicker solder may be used and will allow you to solder larger joints more quickly, but will make soldering small joints difficult and increase the likelihood of creating solder bridges between closely spaced PCB pads. An alloy of 60/40 (60% tin, 40% lead) is used for most electronics work. These days, several lead-free solders are available as well. Kester "44" Rosin Core solder has been a staple of electronics for many years and continues to be available. It is available in several diameters and has a non-corrosive flux.

Remember that when soldering, the solder will release fumes as it is heated. These fumes can be harmful to your eyes and lungs. Therefore, always work in a well ventilated area and avoid breathing the smoke created. Hot solder is also dangerous. It is surprisingly easy to splash hot solder onto yourself, which is a thoroughly unpleasant experience.

**ALWAYS WASH YOUR HANDS AFTER SOLDERING TO REMOVE ANY POTENTIAL LEAD RESIDUE**



# SOLDERING TOOLS & MATERIALS



**A sponge to clean your soldering Iron**

# SOLDERING TOOLS & MATERIALS



## Helping Hands

Are a very useful tool- They are not necessary but are extremely helpful.

There are pairs in the close to use in class or you can purchase your own for around \$7 at American Science and Surplus.

## **Preparing To Solder**

### **Tinning The Soldering Tip**

Before use, a new soldering tip, or one that is very dirty, must be tinned. "Tinning" is the process of coating a soldering tip with a thin coat of solder. This aids in heat transfer between the tip and the component you are soldering, and also gives the solder a base from which to flow from.

### **Step 1: Warm Up The Iron**

Warm up the soldering iron or gun thoroughly. Make sure that it has fully come to temperature because you are about to melt a lot of solder on it. This is especially important if the iron is new because it may have been packed with some kind of coating to prevent corrosion.

### **Step 2: Prepare A Little Space**

While the soldering iron is warming up, prepare a little space to work. Moisten a little sponge and place it in the base of your soldering iron stand or in a dish close by. Lay down a piece of cardboard in case you drip solder (you probably will) and make sure you have room to work comfortably.

### **Step 3: Thoroughly Coat The Tip In Solder**

Thoroughly coat the soldering tip in solder. It is very important to cover the entire tip. You will use a considerable amount of solder during this process and it will drip, so be ready. If you leave any part of the tip uncovered it will tend to collect flux residue and will not conduct heat very well, so run the solder up and down the tip and completely around it to totally cover it in molten solder.



## TINNING THE SOLDERING IRON (the wrong way)



DO NOT tin for the length of time in this video. Tinning should take only a second or two.

DO NOT HOLD THE SOLDER THIS CLOSE TO THE IRON. Heat transfers and holding the solder this close to the tip of the iron could result in burning your fingers

# SOLDERING EXAMPLES

<http://blog.makezine.com/archive/2011/01/skill-set-soldering.html>

# SOLDERING EXAMPLES

[http://www.youtube.com/watch?v=I\\_NU2ruzyc4](http://www.youtube.com/watch?v=I_NU2ruzyc4)

## SOLDER TWO WIRES TOGETHER

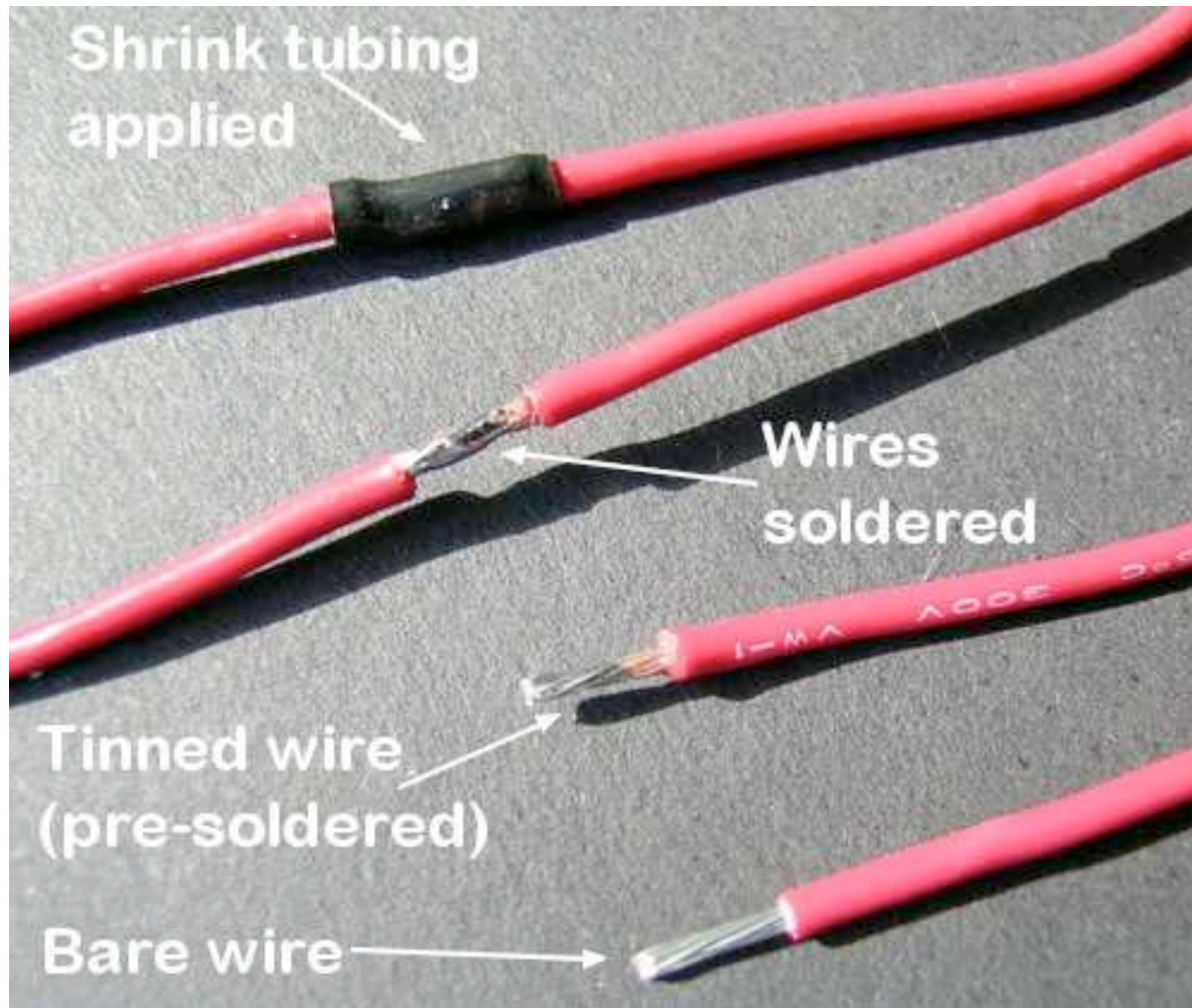

**Use Heat Shrink (use lighter or heat gun to shrink)**



# SOLDER WIRES TO A POTENTIOMETER

## Good Solder Joint

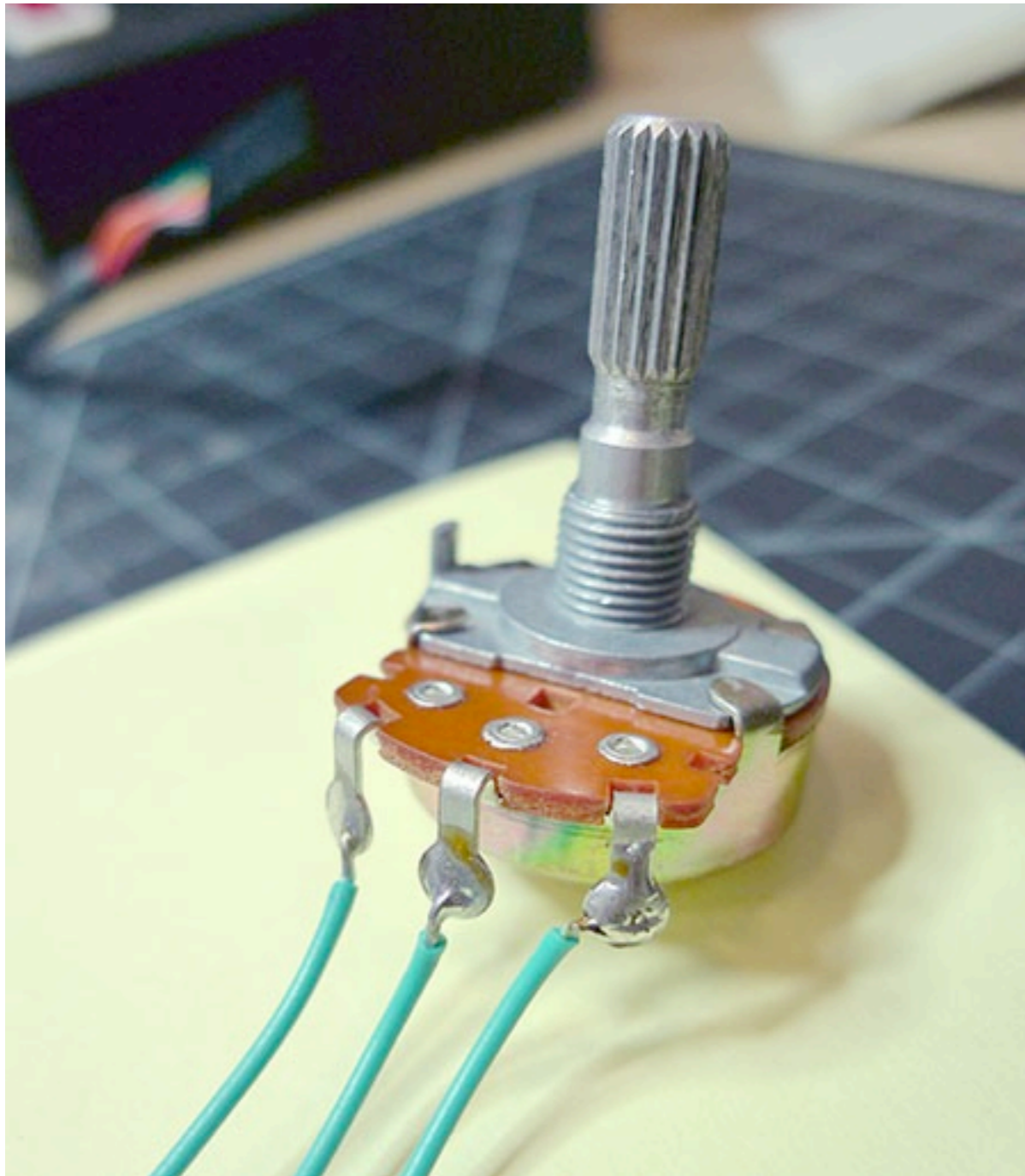

# SOLDER A RESISTOR INTO YOUR PCB BOARD

## Good Solder Joint

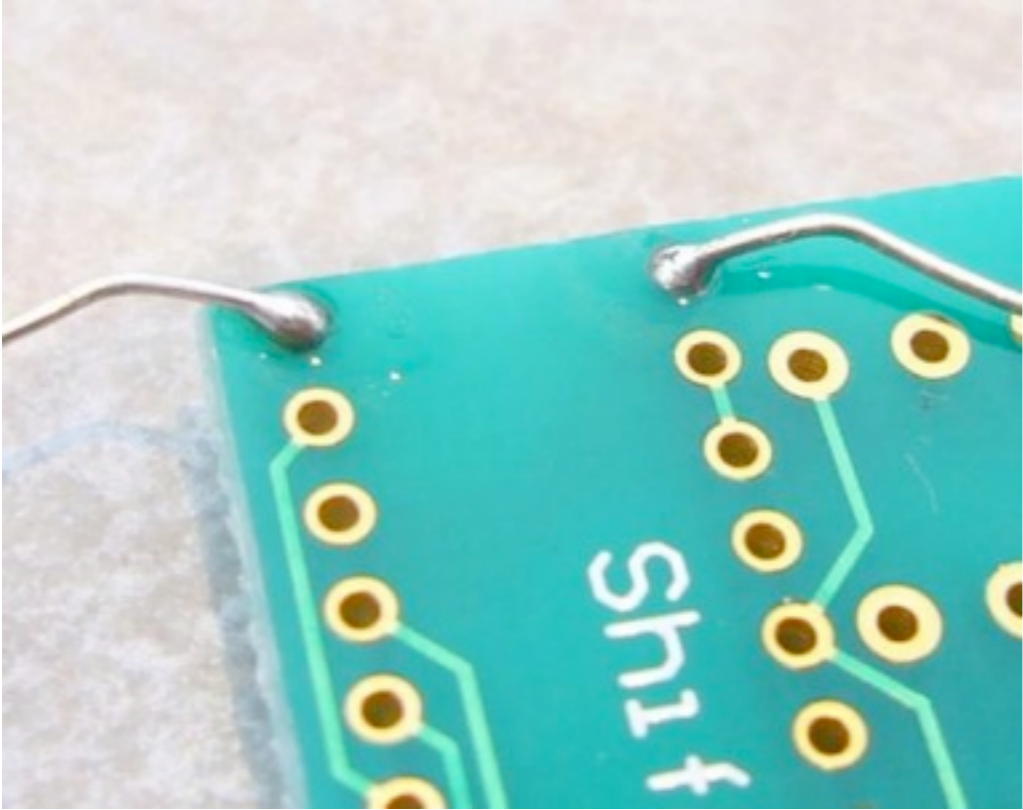

## Bad Solder Joint

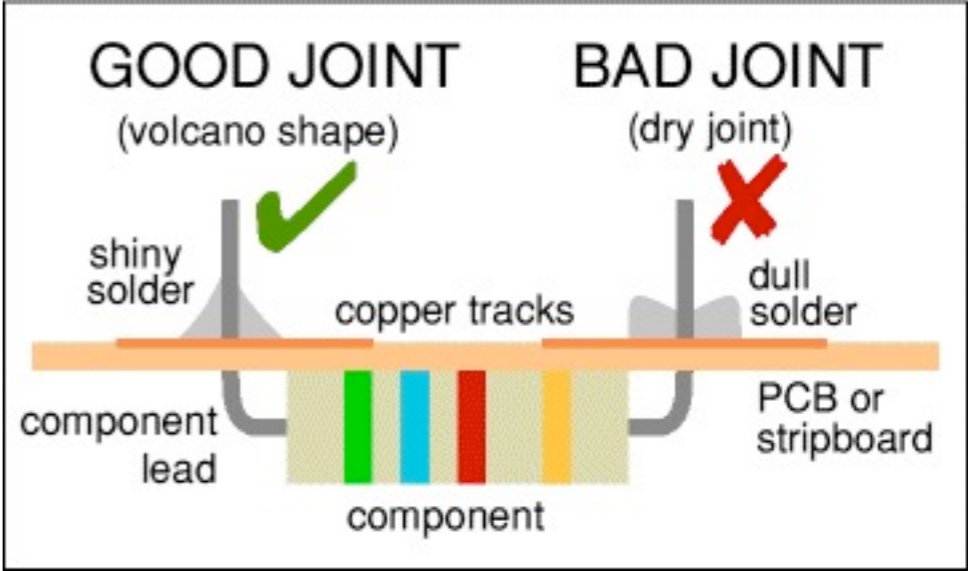
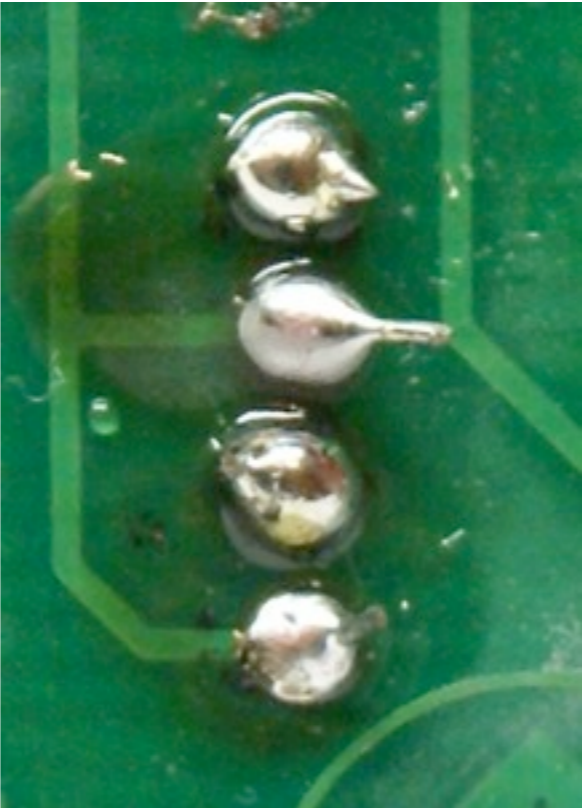



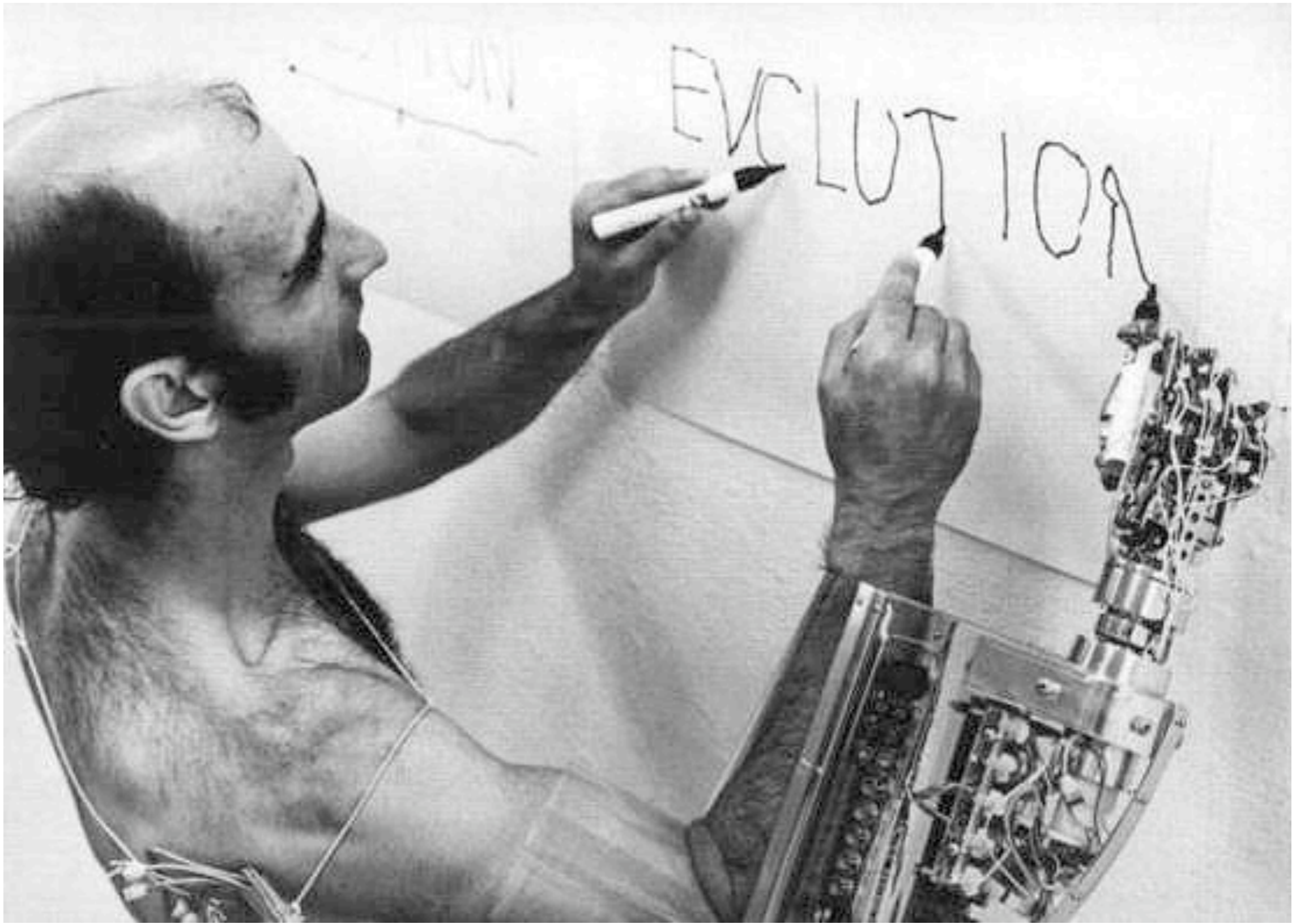

**Artists of the Week**

Stellararc

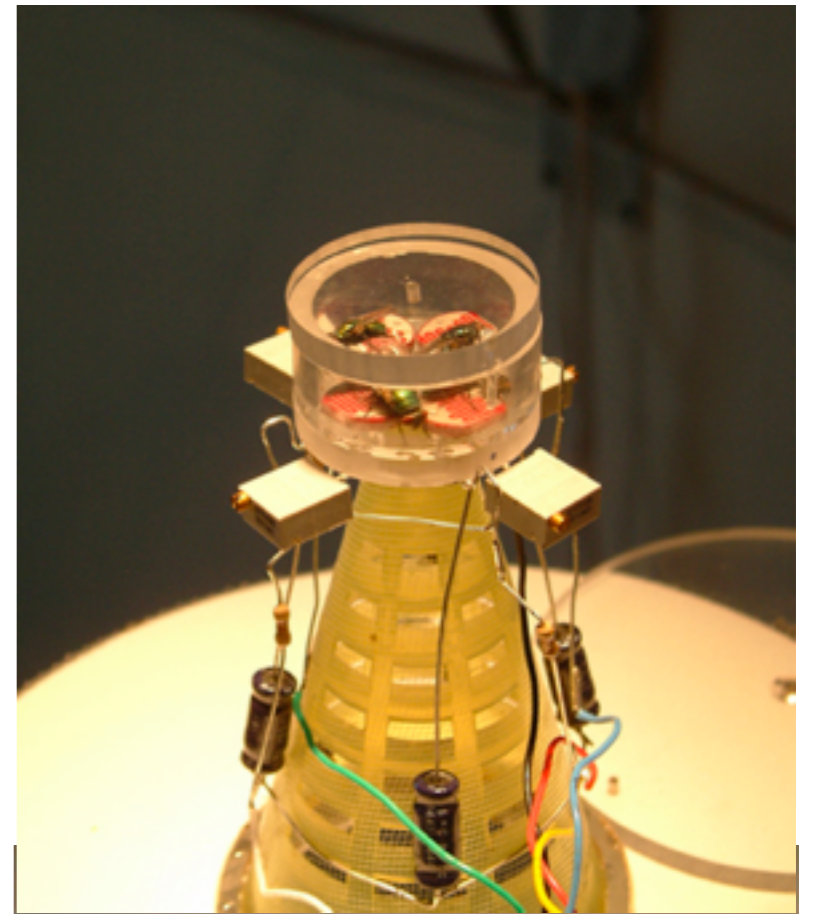

**DAVID BOWEN**



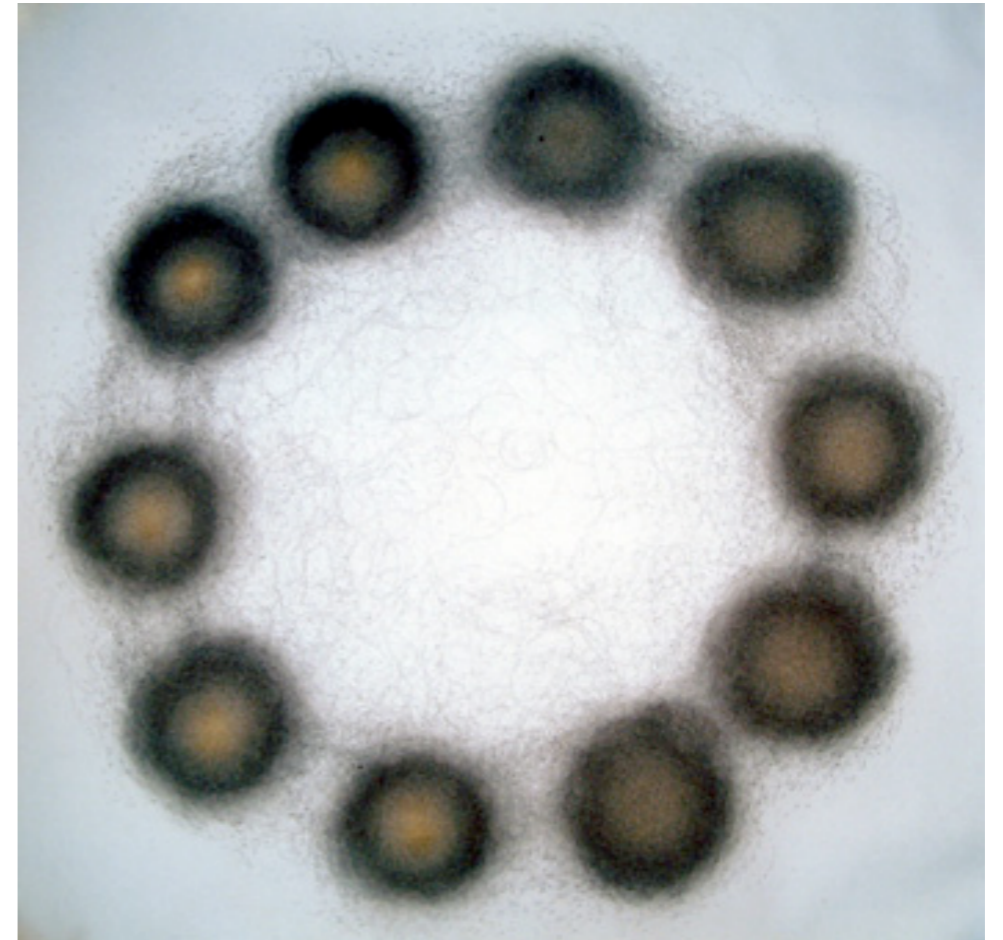
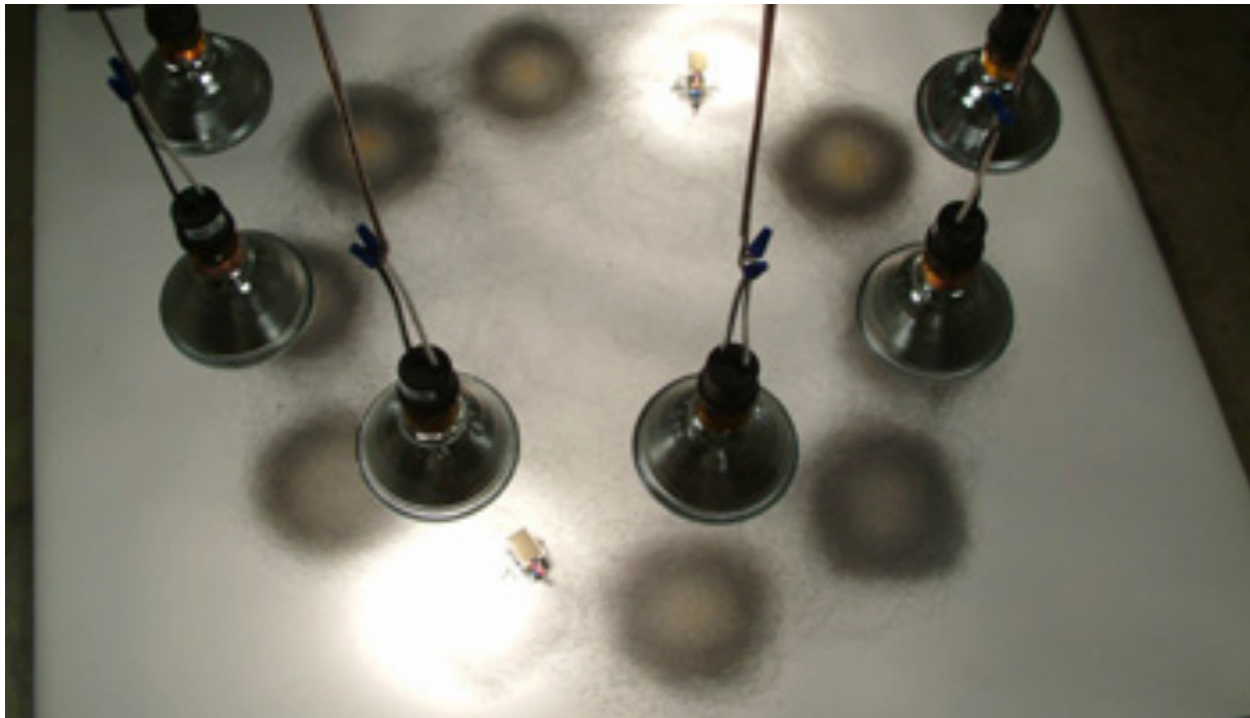
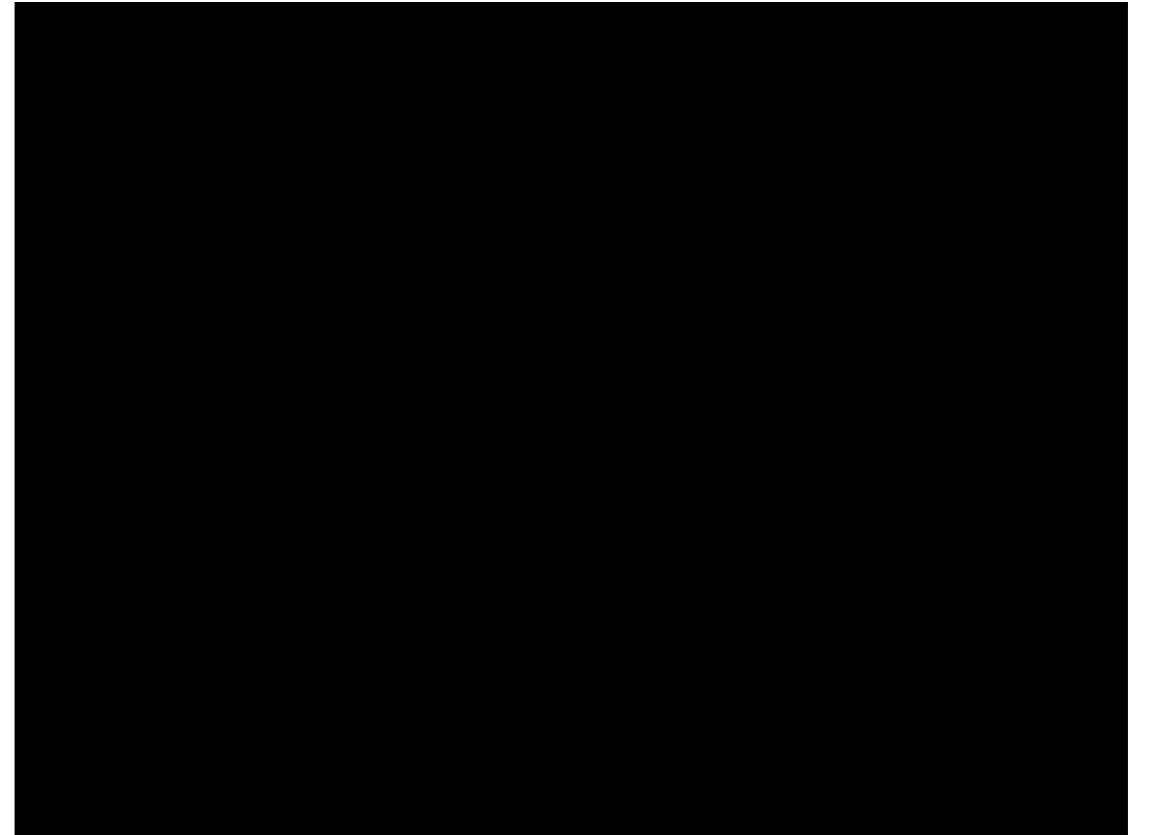
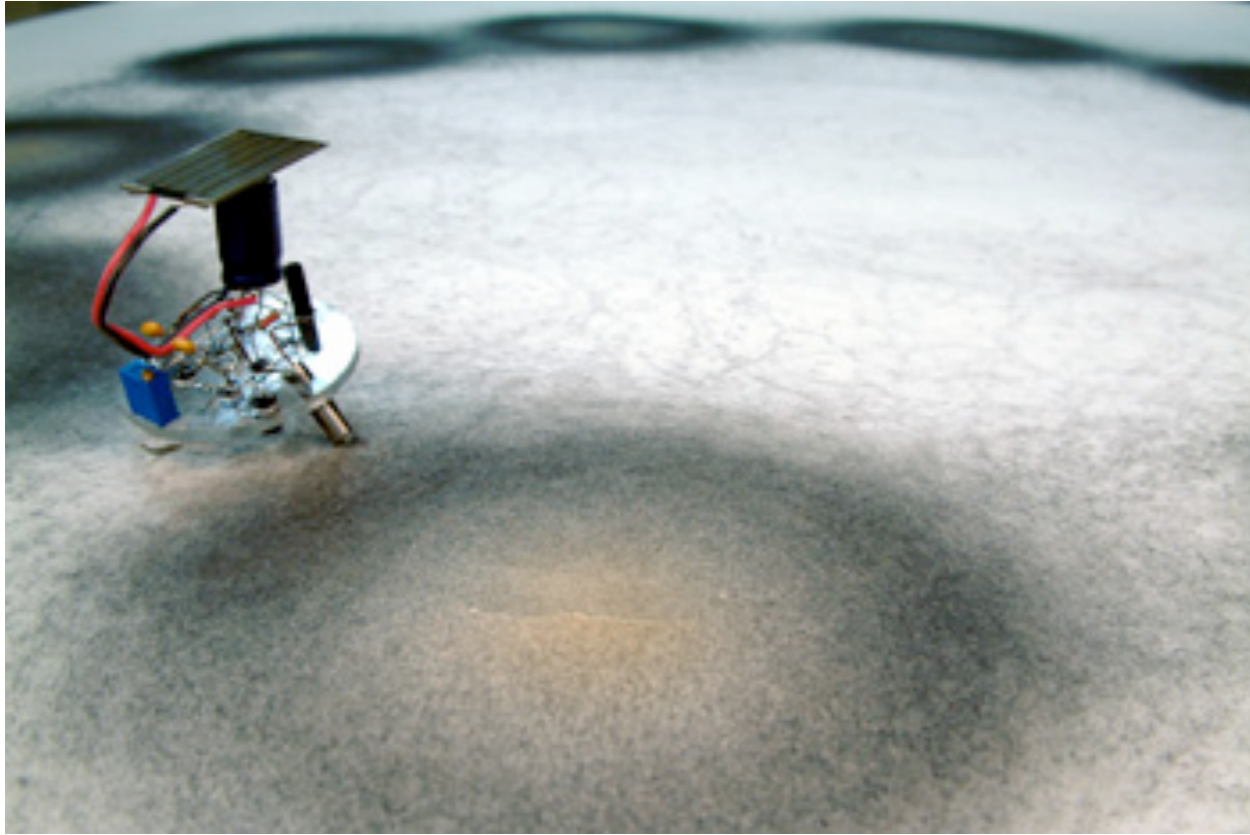

**DAVID BOWEN CONTINUED**

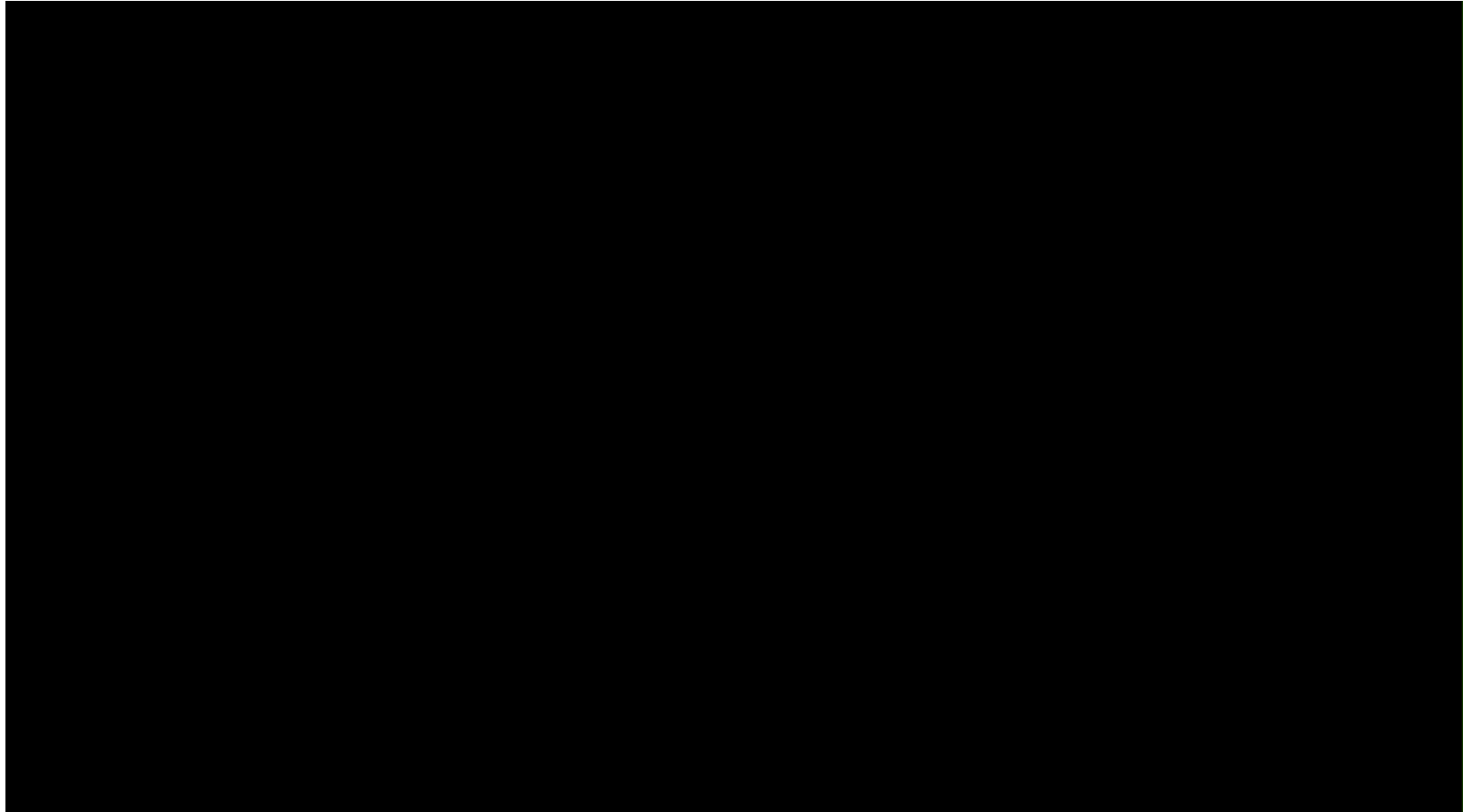

**THEO JANSEN**



## Augmented Fish Reality



## Autotelematic Spider Bots

**KEN RINALDO**





[CAMILLE UTTERBACK- Potent Objects, 2002](#)



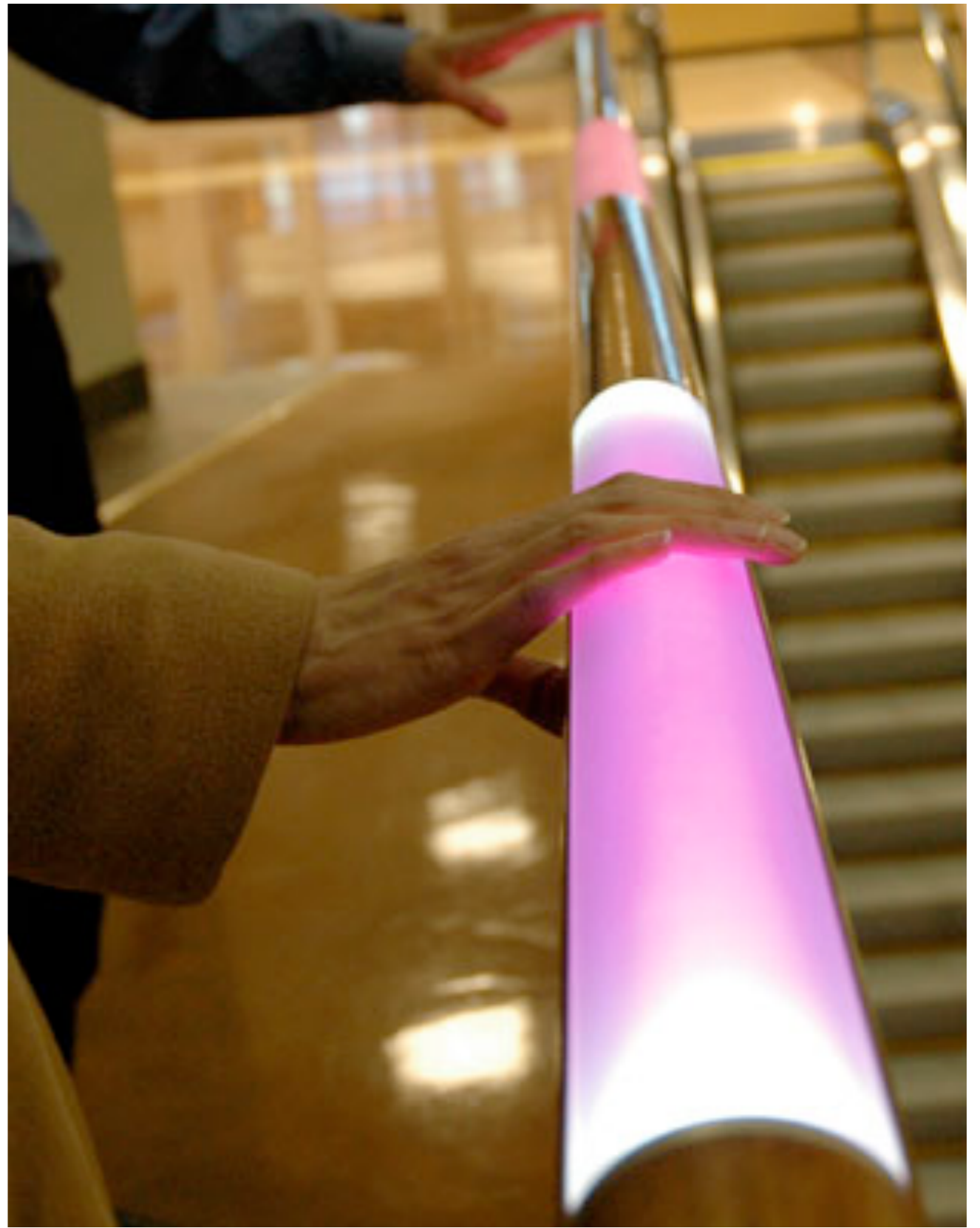

**CAMILLE UTTERBACK- Aurora Organ, 2009**

# JANET CARDIFF



The action of passing your hands over the surface of an old carpenter's table elicits an aural response from audio speakers around the small room. A couple impart their bodily passion while other voices disclose mysterious dream-like events reminiscent of a cinematic suspense thriller. These voices mingle among the familiar sounds of a car screeching, telephone ringing, a knife being sharpened, a gun shot, movie music, a woman softly reciting the alphabet. The viewers' hands orchestrate this collage, composing layered and provisional tales.



# JANET CARDIFF



CABINET OF CURIOSITIES, 2010



KILLING MACHINE, 2008